

Thiele Star Series™ Bag Filling Systems



UltraStar

Design Features

- Simple straight-through clean design
- Runs large multi-wall paper, poly, polywoven and polyethylene non-gusseted bags
- Independant upper and lower bag transfer drive systems for square presentation to a variety of sealing systems
- Single or dual filling spouts
- Superior bag top control for excellent seals
- Automatic reject of unsatisfactory bags for high efficiency
- High speed servo design



OmniStar

Star Series Bag Filling Systems

The Star Series™ mid-and-large bag filling systems from BW Flexible Systems offer several exclusive benefits aimed at increasing efficiency and accuracy, reducing sealing failures and waste, and delivering the quickest changeovers in the industry. The simple straight-through design with servo controls helps achieve packaging speeds of up to 20 bags/min with the OmniStar, and 38 bags/min with the UltraStar and its two filling spouts.

Industries Served

- Pet Food
- Rice
- Sugar/Salt
- Powders
- Seed
- Fertilizer
- Feed
- Chemicals

Key Benefits

- Unique configurable internal bag sealing system
- Downtime Monitor tracks upstream and downstream functions and graphically displays faults and duration
- Quick automated changeover via bag barcode scanner
- On-time maintenance through HMI scheduling reminders
- Star System + MasterWeigh scales deliver full system integration and automated changeover

Operational Features

- Fully integrated PLC control system with common HMI for both scale and bagger
- Integrated bag monitoring - rejects unacceptable bags
- Internal VPN router for remote troubleshooting
- Integrated on-bag printing systems
- Bag deflation system
- Bag-top registration

Specifications

Production Speed

OmniStar up to 20 BPM
UltraStar up to 38 BPM

Empty Bag Sizes

Face Width: 11"-19"
297mm - 483mm
Length: 14"-40"
355mm - 1016mm

*Other sizes per review

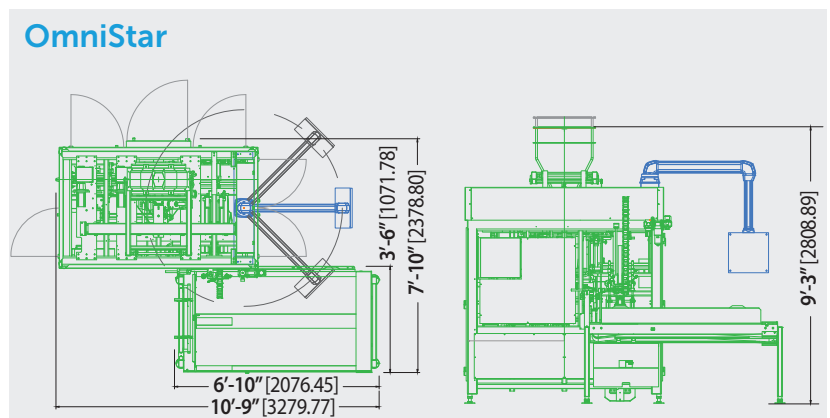
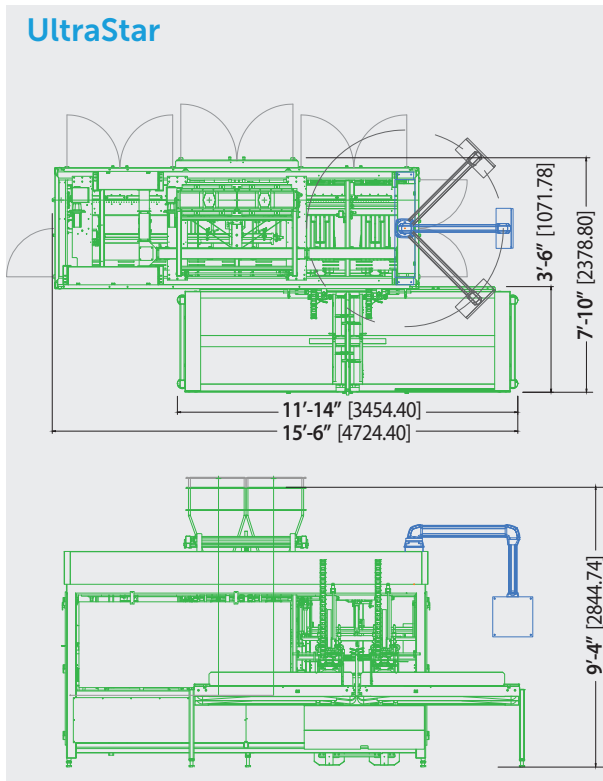

Hayssen | Rose Forgrove | Sandiacre | Schib | Simionato | Streamfeeder | SYMACH | Thiele

BW Flexible Systems is a global manufacturer of packaging systems that fill and bag thousands of food and non-food products. Our packaging systems are designed and manufactured to maximize the efficiency and lifetime value of our customers' packaging lines. Our range of machinery includes form-fill-seal, feeding, bag filling and sealing, pouch-making equipment, flow-wrap, reclosable packaging solutions, palletizing, stretch-wrapping and more. For more information, go to bwflexiblesystems.com 09.2019

